

Zeitprobleme bei kritischen Übergängen

Digitale Systeme

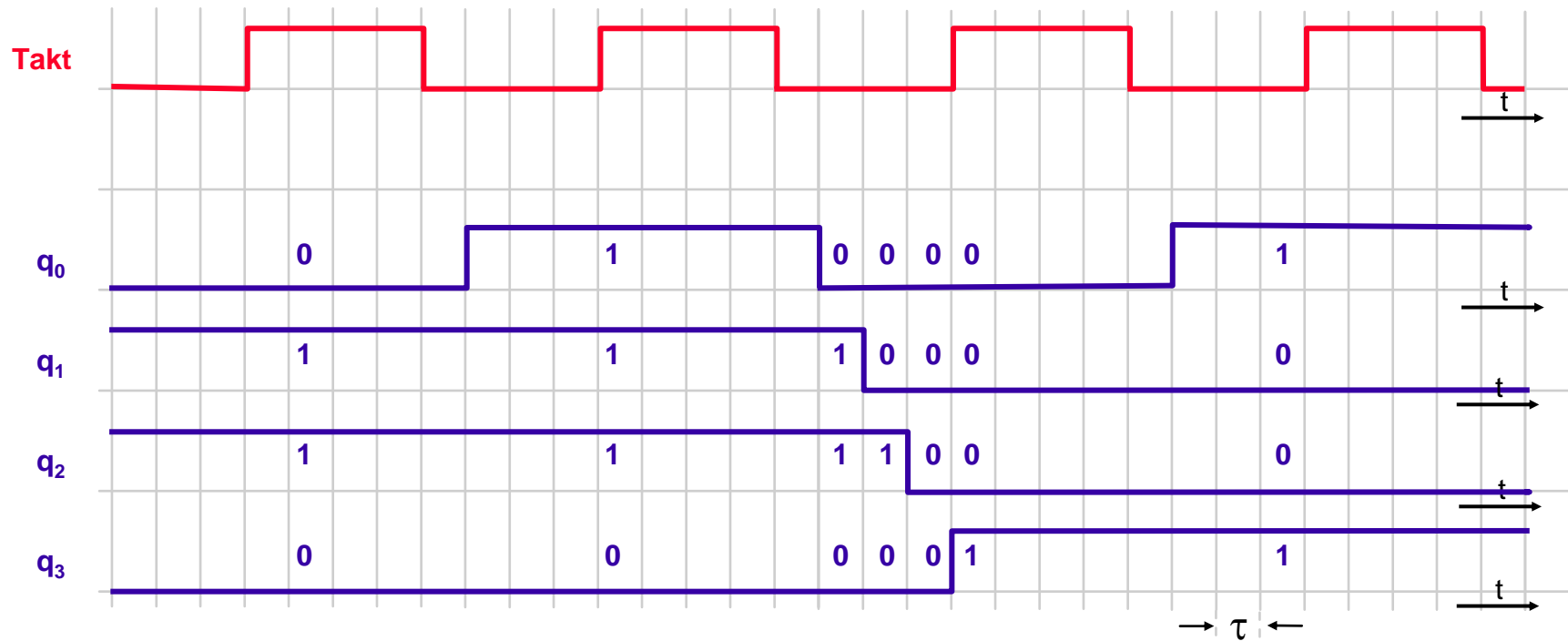

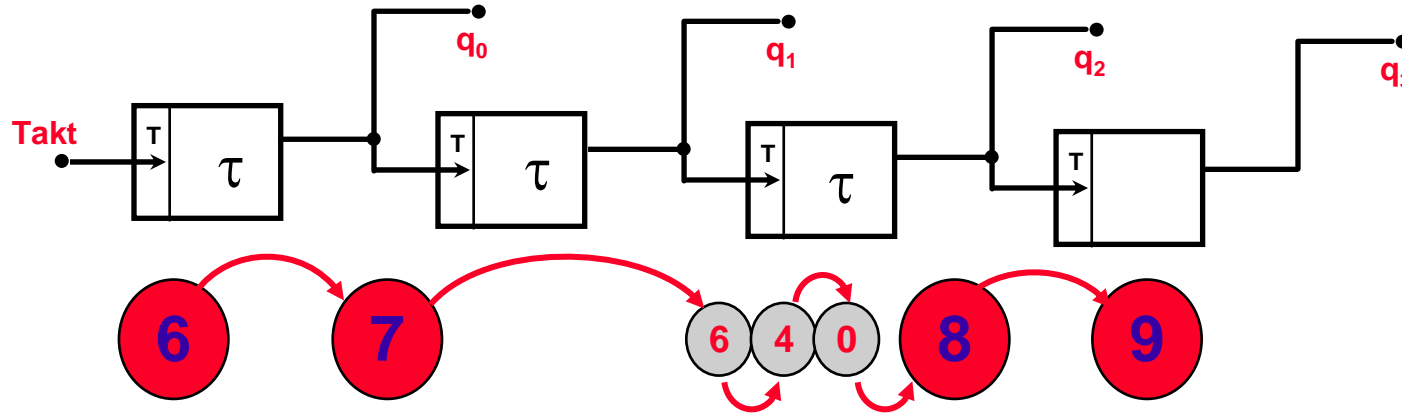

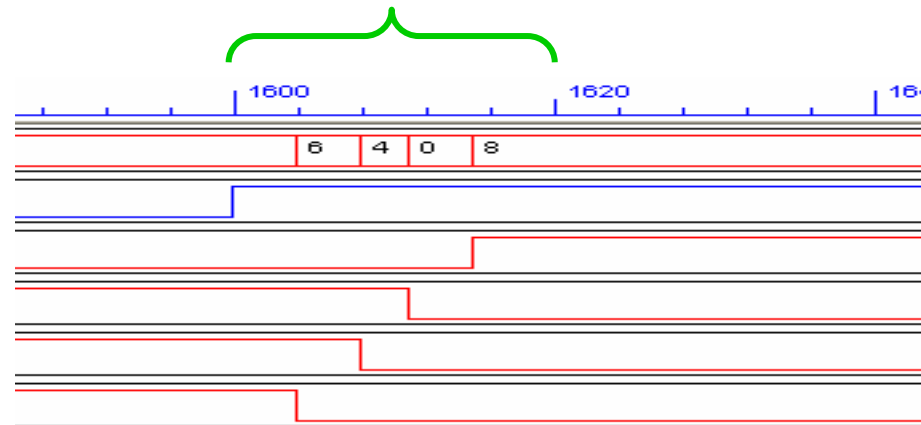
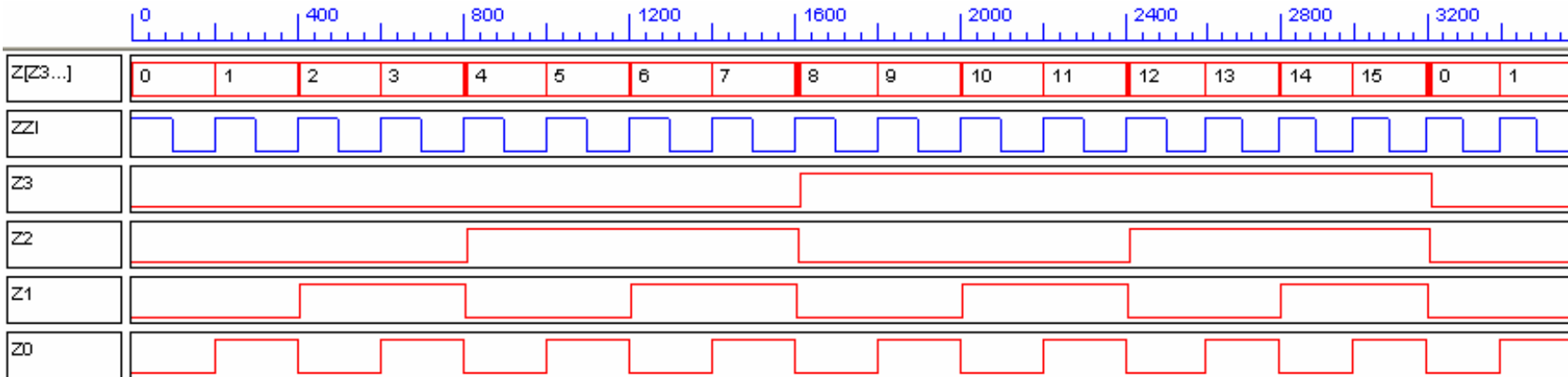
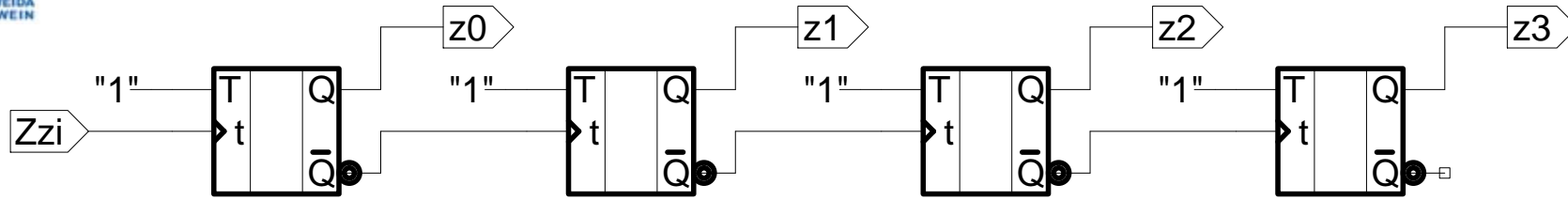
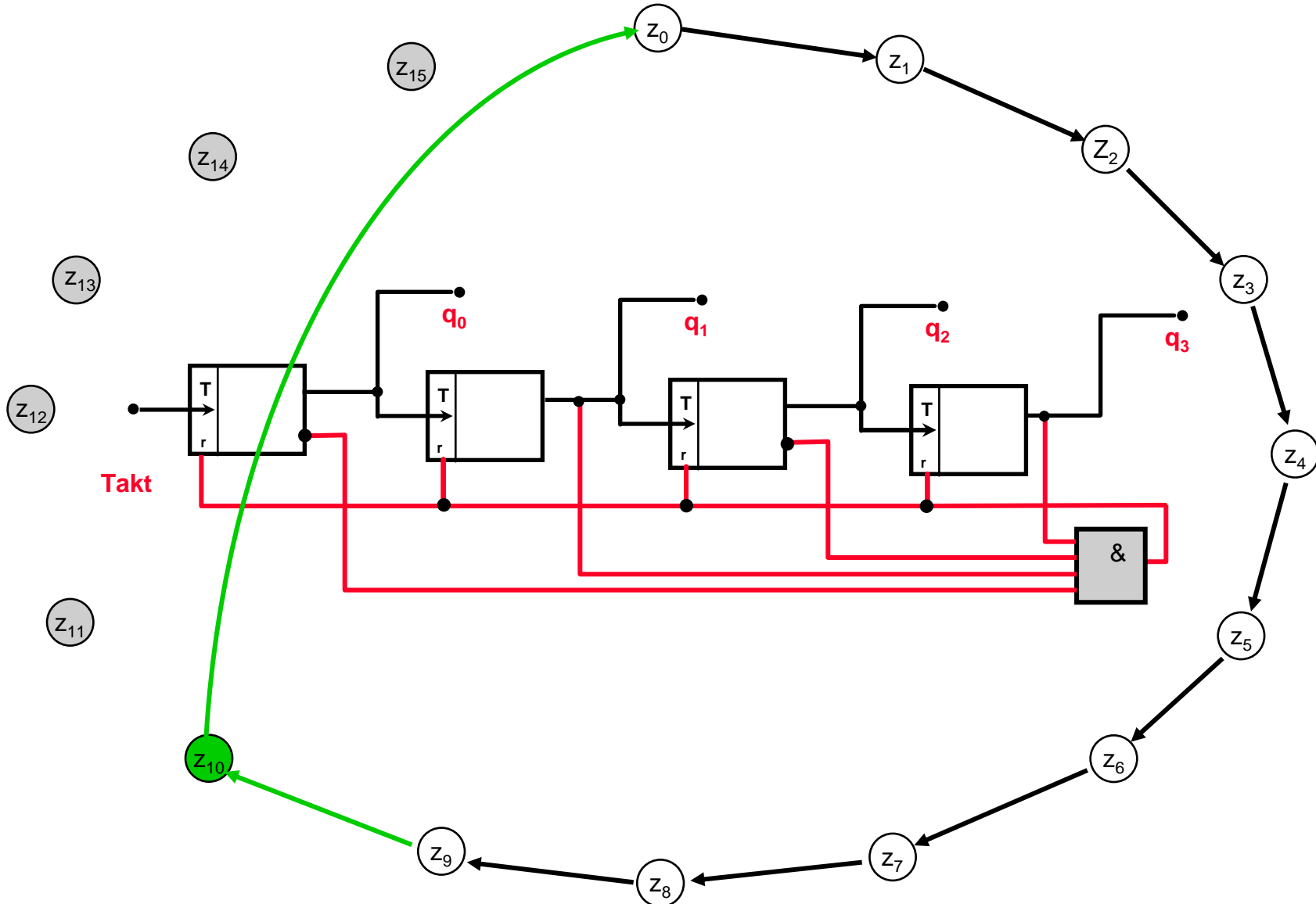

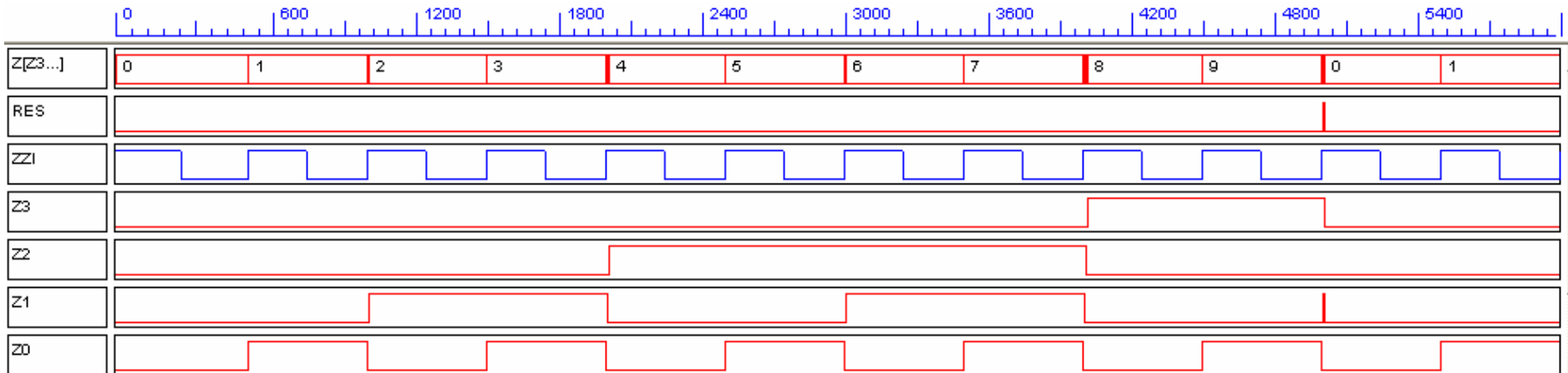
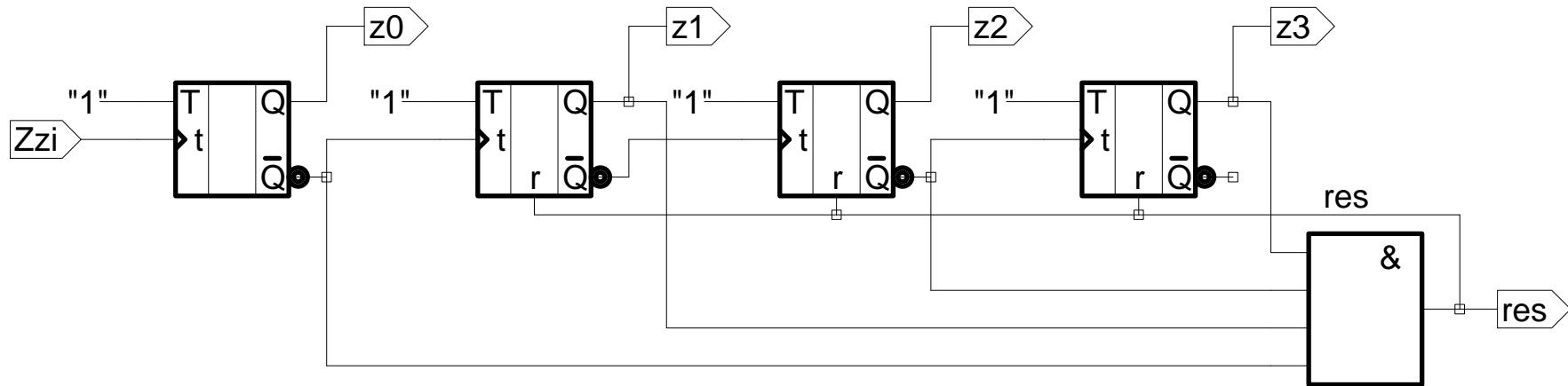

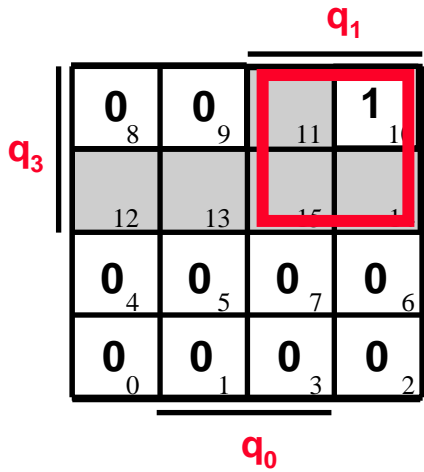

$$r = q_1 \cdot q_3$$

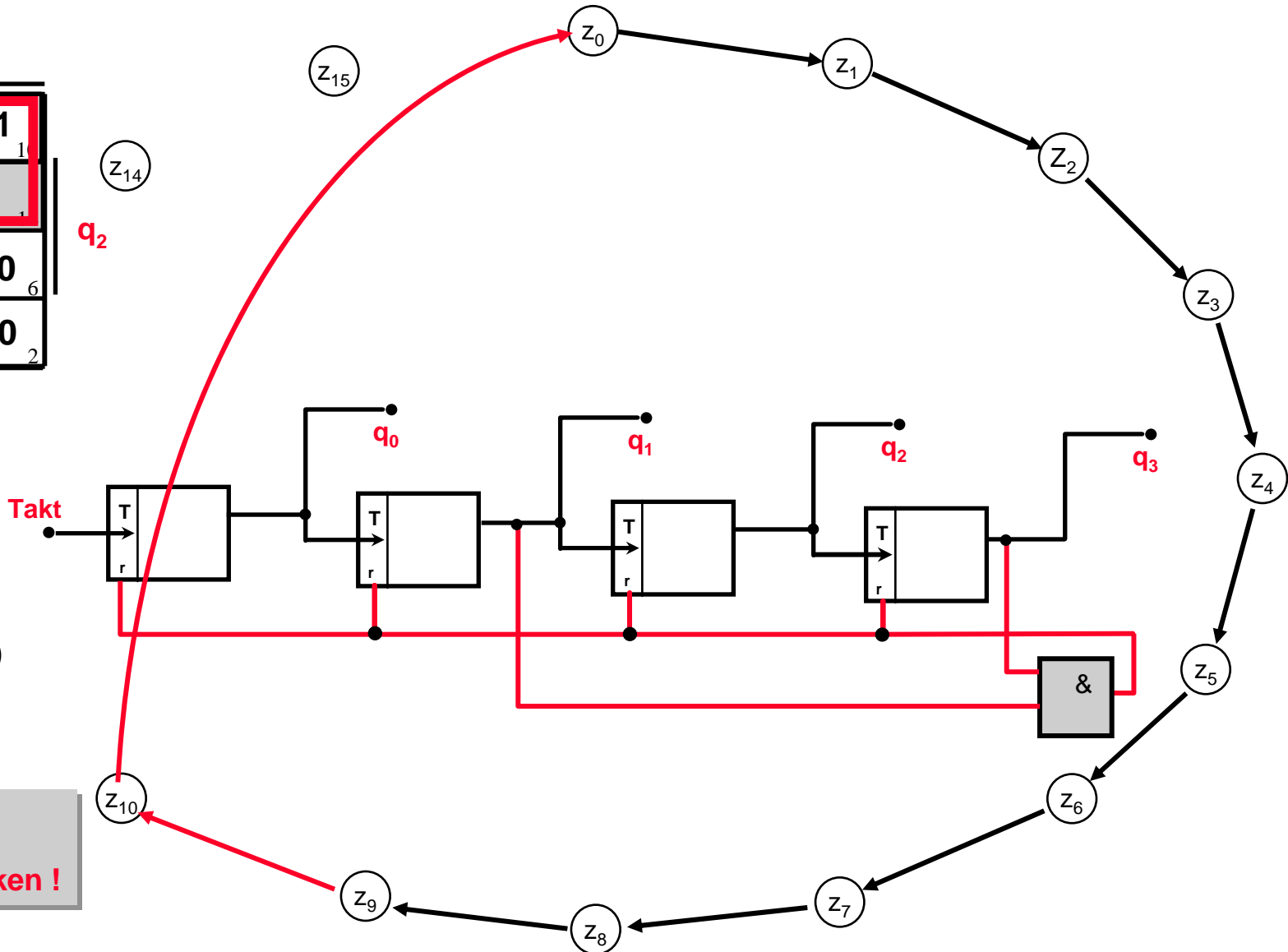

Beim Übergang von Z_{10} nach Z_0 entstehen an q_1 und q_3 Rückflanken !

Zeitprobleme beim Rücksetzen

Digitale Systeme

Der Übergang von Z_9 nach Z_0 wird als Hasard ausgeführt!

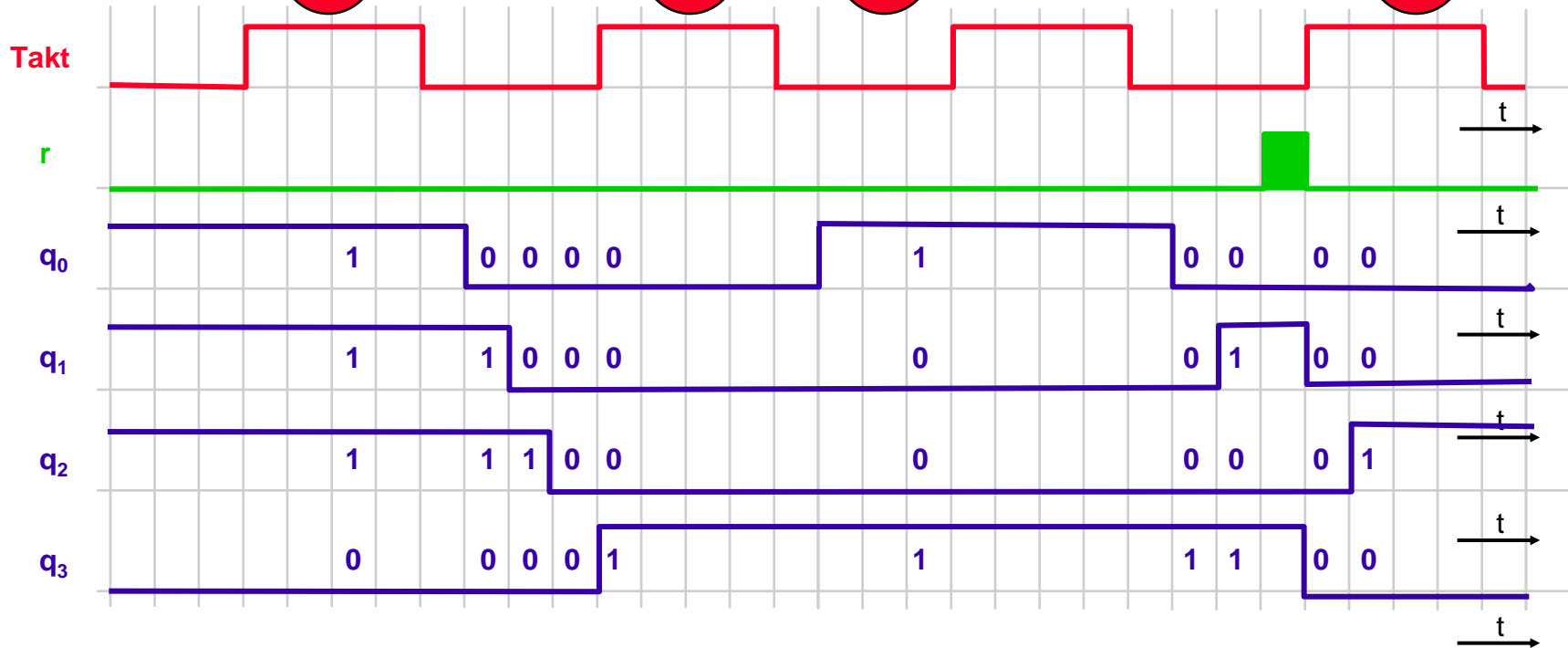
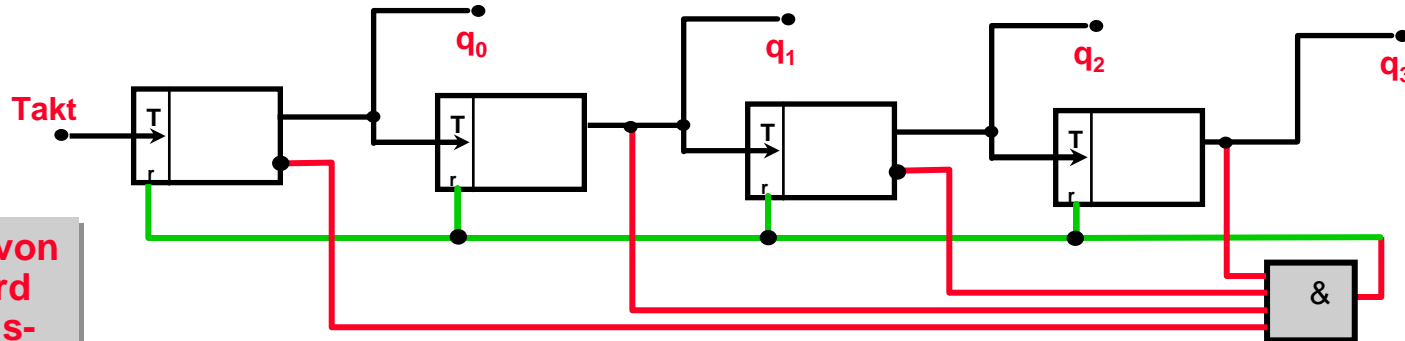

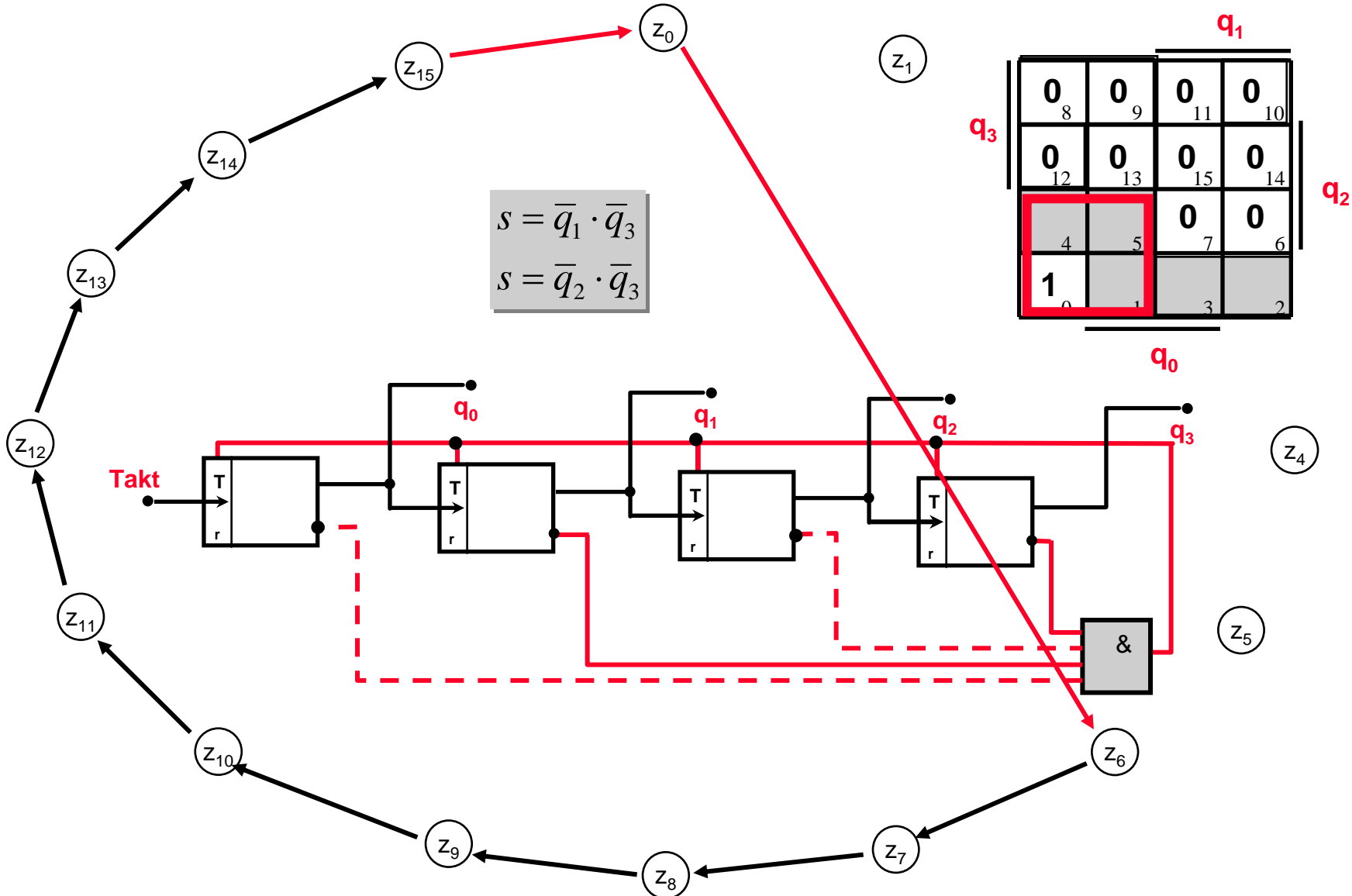

Z ^t	Q ^{t+3} ₃	Q ^{t+2} ₂	Q ^{t+1} ₁	Q ^t ₀	x ^t	Q ^{t+3} ₃	Q ^{t+2} ₂	Q ^{t+1} ₁	Q ^t ₀	Z ^{t+1}
0	0	0	0	0	0	0	0	0	0	0
0	0	0	0	0	1	0	0	0	1	1
1	0	0	0	1	0	0	0	1	0	2
1	0	0	0	1	1	0	0	1	1	3
2	0	0	1	0	0	0	1	0	0	4
2	0	0	1	0	1	0	1	0	1	5
3	0	0	1	1	0	0	1	1	0	6
3	0	0	1	1	1	0	1	1	1	7
4	0	1	0	0	0	1	0	0	0	8
4	0	1	0	0	1	1	0	0	1	9
5	0	1	0	1	0	1	0	1	0	10
5	0	1	0	1	1	1	0	1	1	11
6	0	1	1	0	0	1	1	0	0	12
6	0	1	1	0	1	1	1	0	1	13
7	0	1	1	1	0	1	1	1	0	14
7	0	1	1	1	1	1	1	1	1	15
8	1	0	0	0	0	0	0	0	0	0
8	1	0	0	0	1	0	0	0	1	1
9	1	0	0	1	0	0	0	1	0	2
9	1	0	0	1	1	0	0	1	1	3
10	1	0	1	0	0	0	1	0	0	4
10	1	0	1	0	1	0	1	0	1	5
11	1	0	1	1	0	0	1	1	0	6
11	1	0	1	1	1	0	1	1	1	7
12	1	1	0	0	0	1	0	0	0	8
12	1	1	0	0	1	1	0	0	1	9
13	1	1	0	1	0	1	0	1	0	10
13	1	1	0	1	1	1	0	1	1	11
14	1	1	1	0	0	1	1	0	0	12
14	1	1	1	0	1	1	1	0	1	13
15	1	1	1	1	0	1	1	1	0	14
15	1	1	1	1	1	1	1	1	1	15

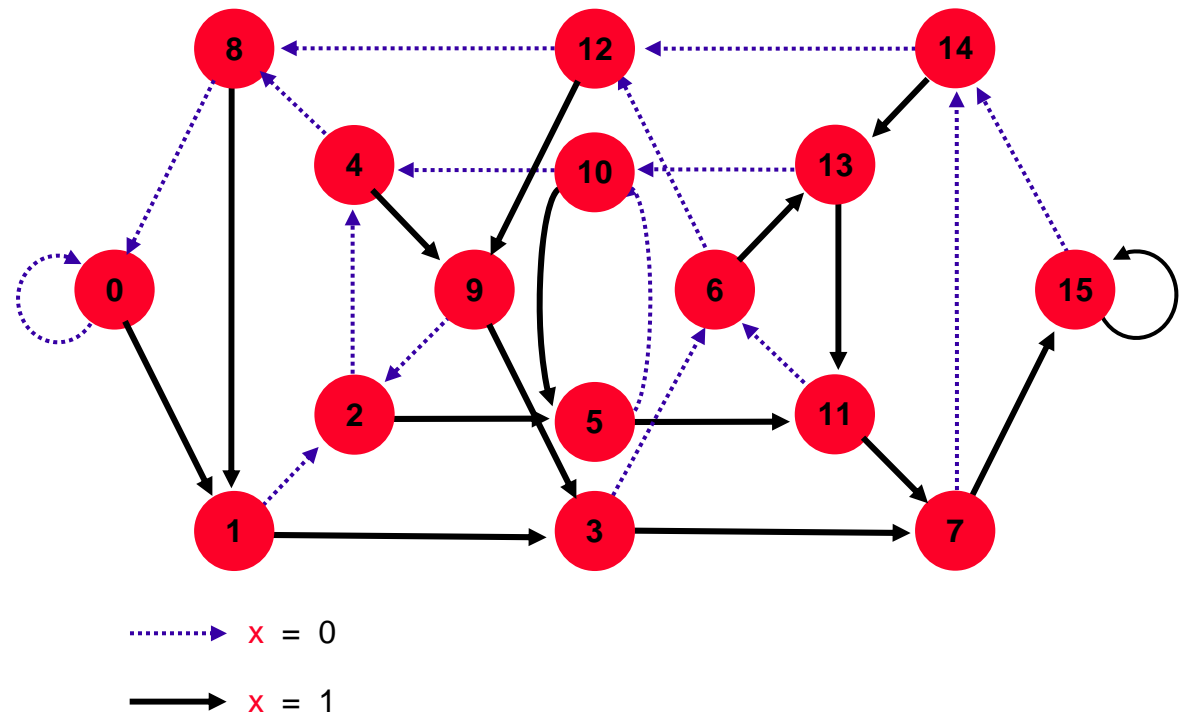
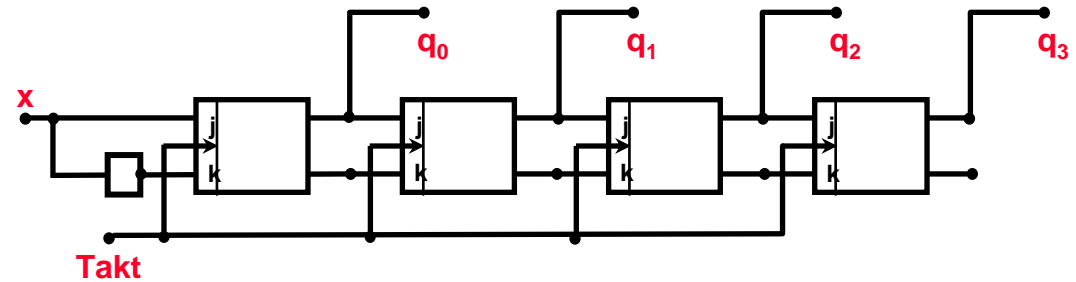

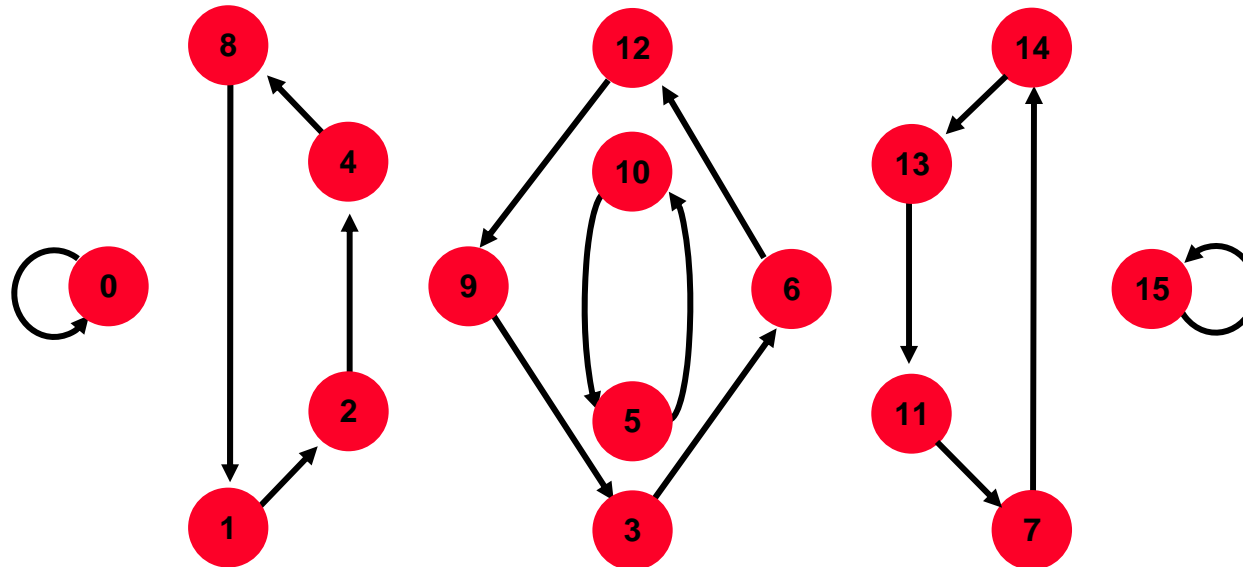
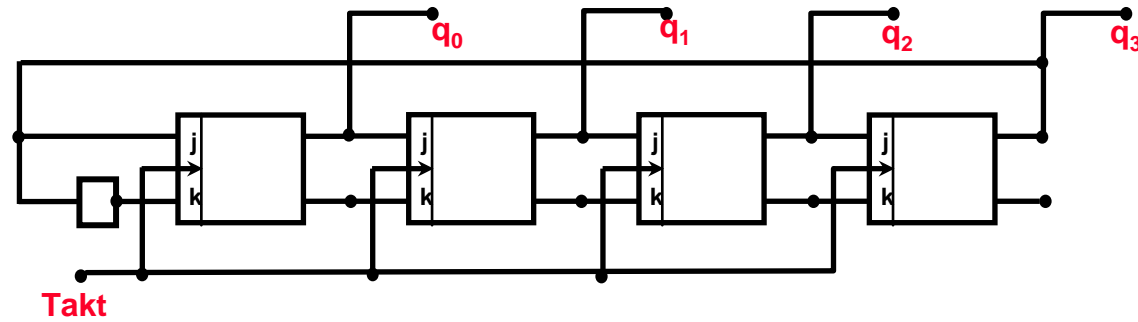

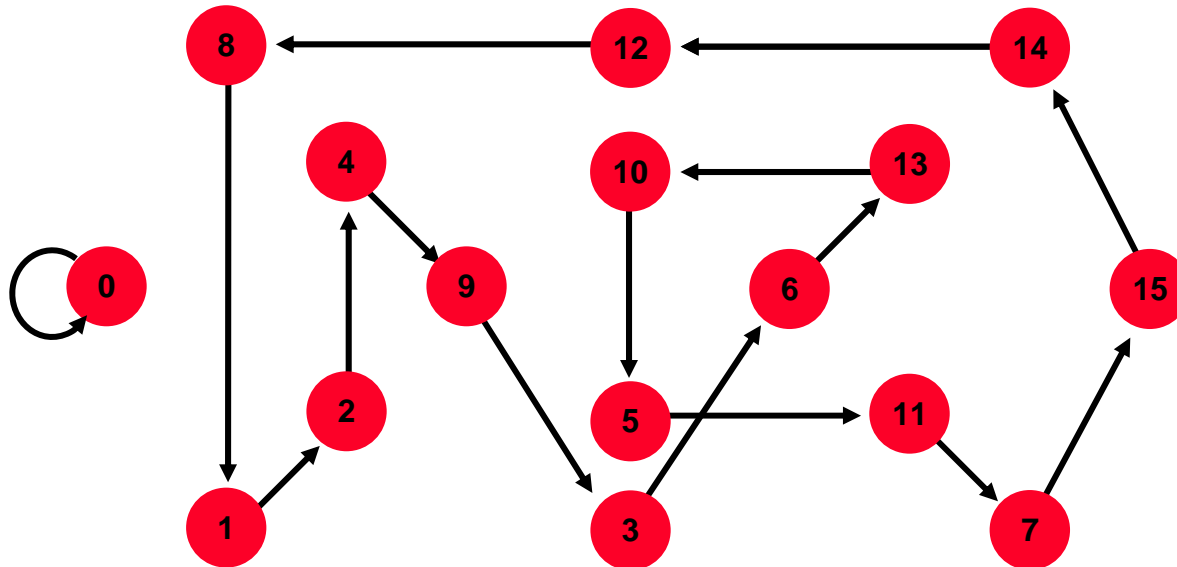
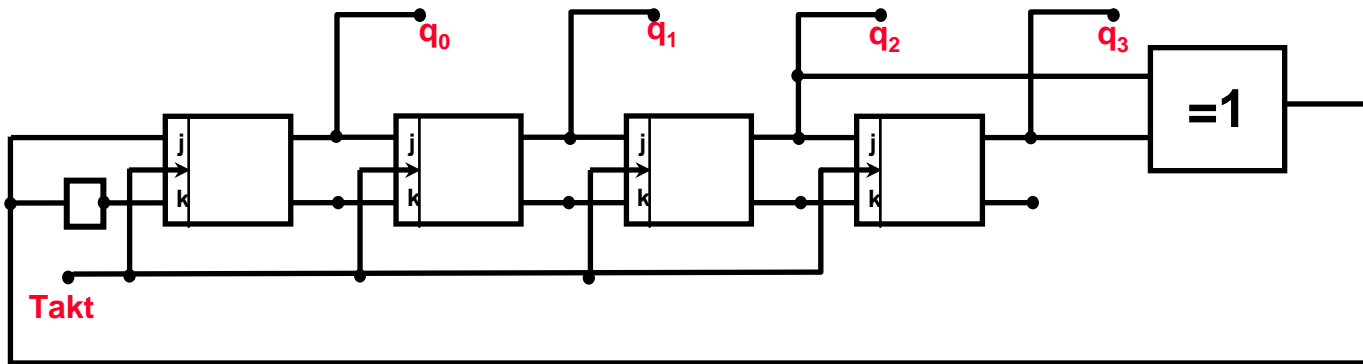

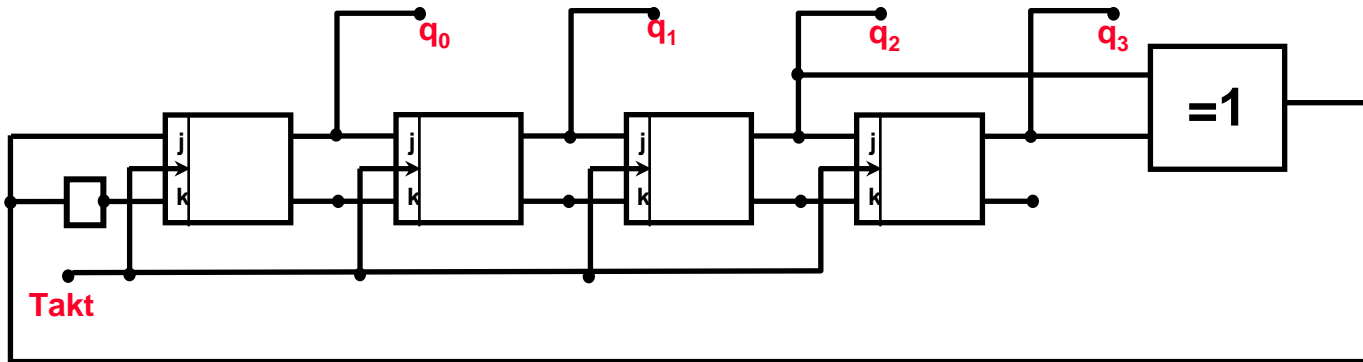

Z^t	q_3^t	q_2^t	q_1^t	q_0^t	q_3^{t+1}	q_2^{t+1}	q_1^{t+1}	q_0^{t+1}	Z^{t+1}
0	0	0	0	0	0	0	0	0	0
1	0	0	0	1	0	0	1	0	2
2	0	0	1	0	0	1	0	0	4
3	0	0	1	1	0	1	1	0	6
4	0	1	0	0	1	0	0	1	9
5	0	1	0	1	1	0	1	1	11
6	0	1	1	0	1	1	0	1	13
7	0	1	1	1	1	1	1	1	15
8	1	0	0	0	0	0	0	1	1
9	1	0	0	1	0	0	1	1	3
10	1	0	1	0	0	1	0	1	5
11	1	0	1	1	0	1	1	1	7
12	1	1	0	0	1	0	0	0	8
13	1	1	0	1	1	0	1	0	10
14	1	1	1	0	1	1	0	0	12
15	1	1	1	1	1	1	1	0	14

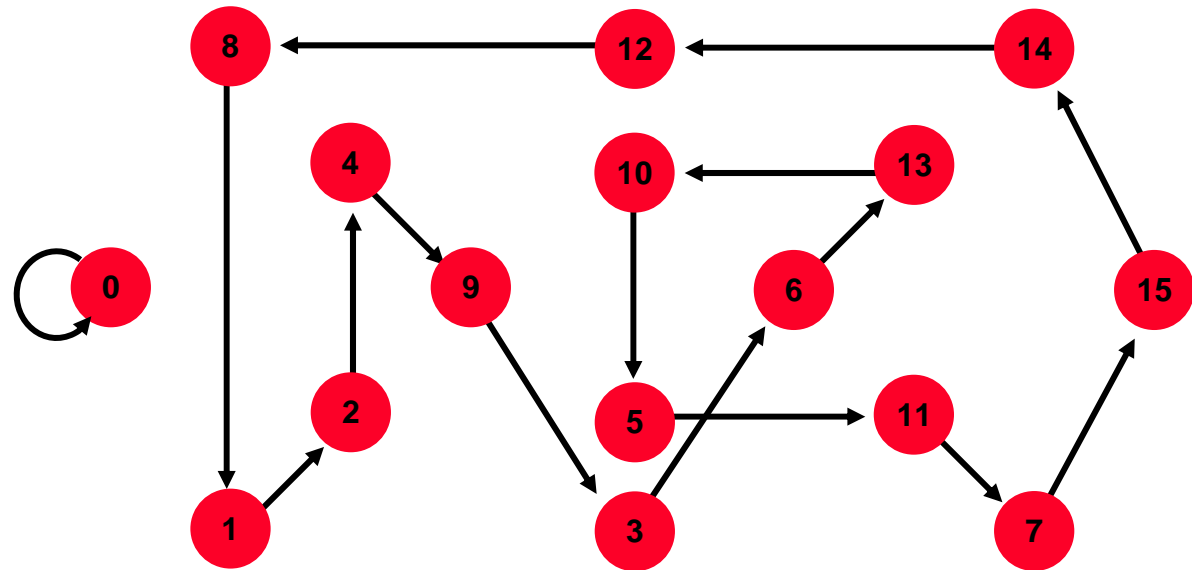

Invers zurückgeführtes Schieberegister Zustandsfolgen

Digitale Systeme

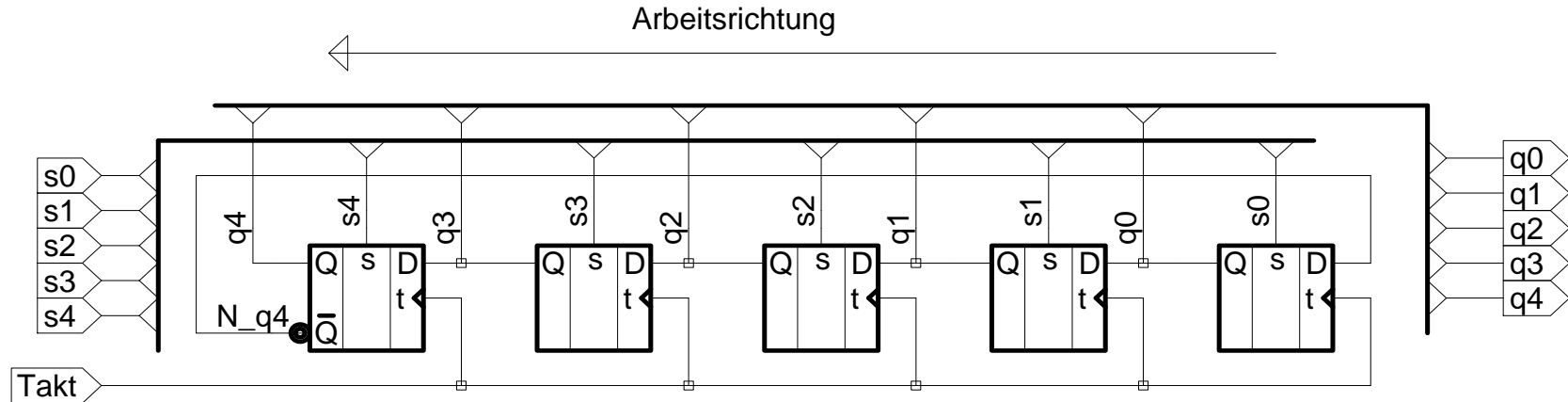

Z _i	q ₄	q ₃	q ₂	q ₁	q ₀
0	0	0	0	0	0
1	0	0	0	0	1
3	0	0	0	1	1
7	0	0	1	1	1
15	0	1	1	1	1
31	1	1	1	1	1
30	1	1	1	1	0
28	1	1	1	0	0
24	1	1	0	0	0
16	1	0	0	0	0
0	0	0	0	0	0

Z _i	q ₄	q ₃	q ₂	q ₁	q ₀
2	0	0	0	1	0
5	0	0	1	0	1
11	0	1	0	1	1
23	1	0	1	1	1
14	0	1	1	1	0
29	1	1	1	0	1
26	1	1	0	1	0
20	1	0	1	0	0
8	0	1	0	0	0
17	1	0	0	0	1
2	0	0	0	1	0

Z _i	q ₄	q ₃	q ₂	q ₁	q ₀
4	0	0	1	0	0
9	0	1	0	0	1
19	1	0	0	1	1
6	0	0	1	1	0
13	0	1	1	0	1
27	1	1	0	1	1
22	1	0	1	1	0
12	0	1	1	0	0
25	1	1	0	0	1
18	1	0	0	1	0
4	0	0	1	0	0

Z _i	q ₄	q ₃	q ₂	q ₁	q ₀
10	0	1	0	1	0
21	1	0	1	0	1
10	0	1	0	1	0

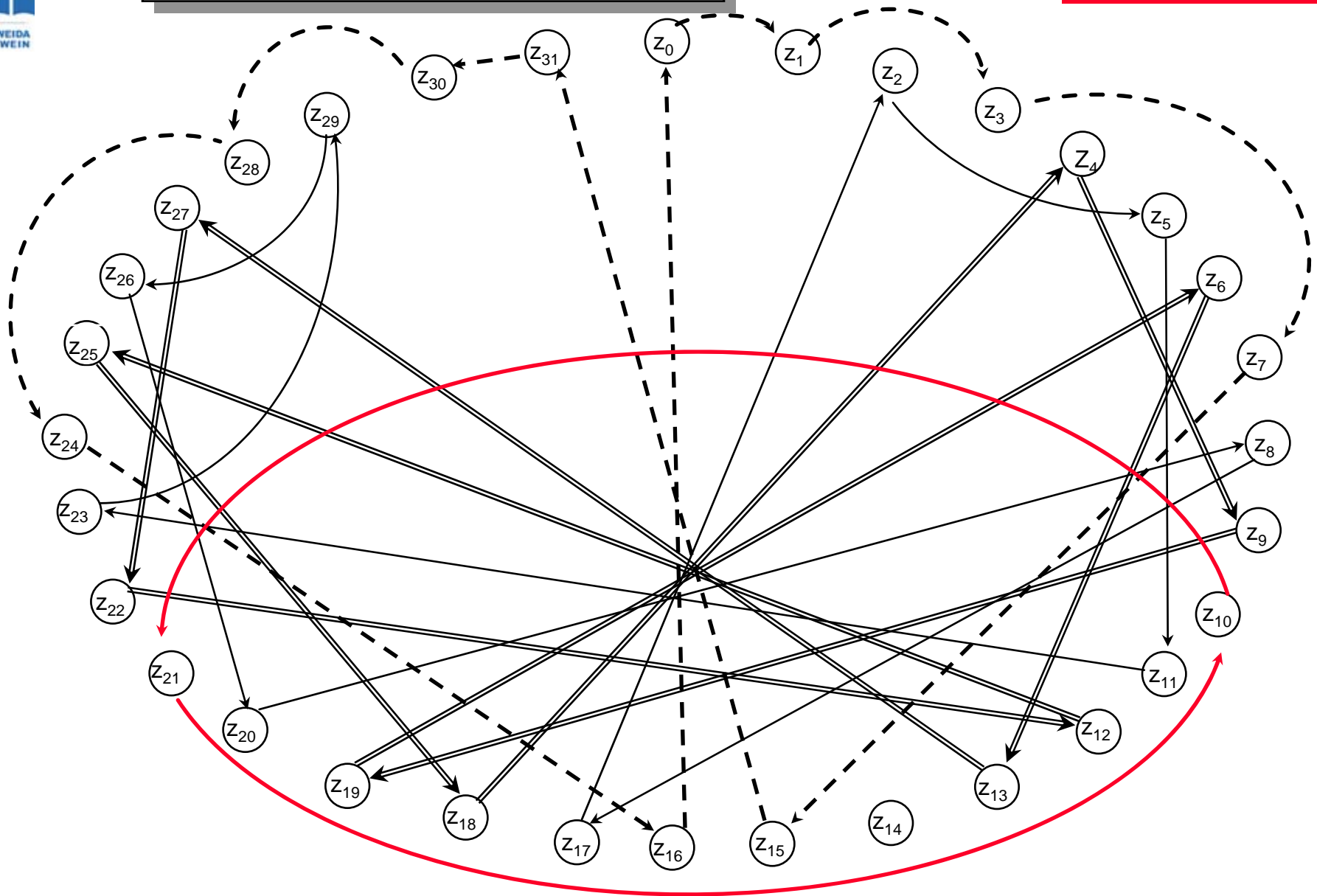

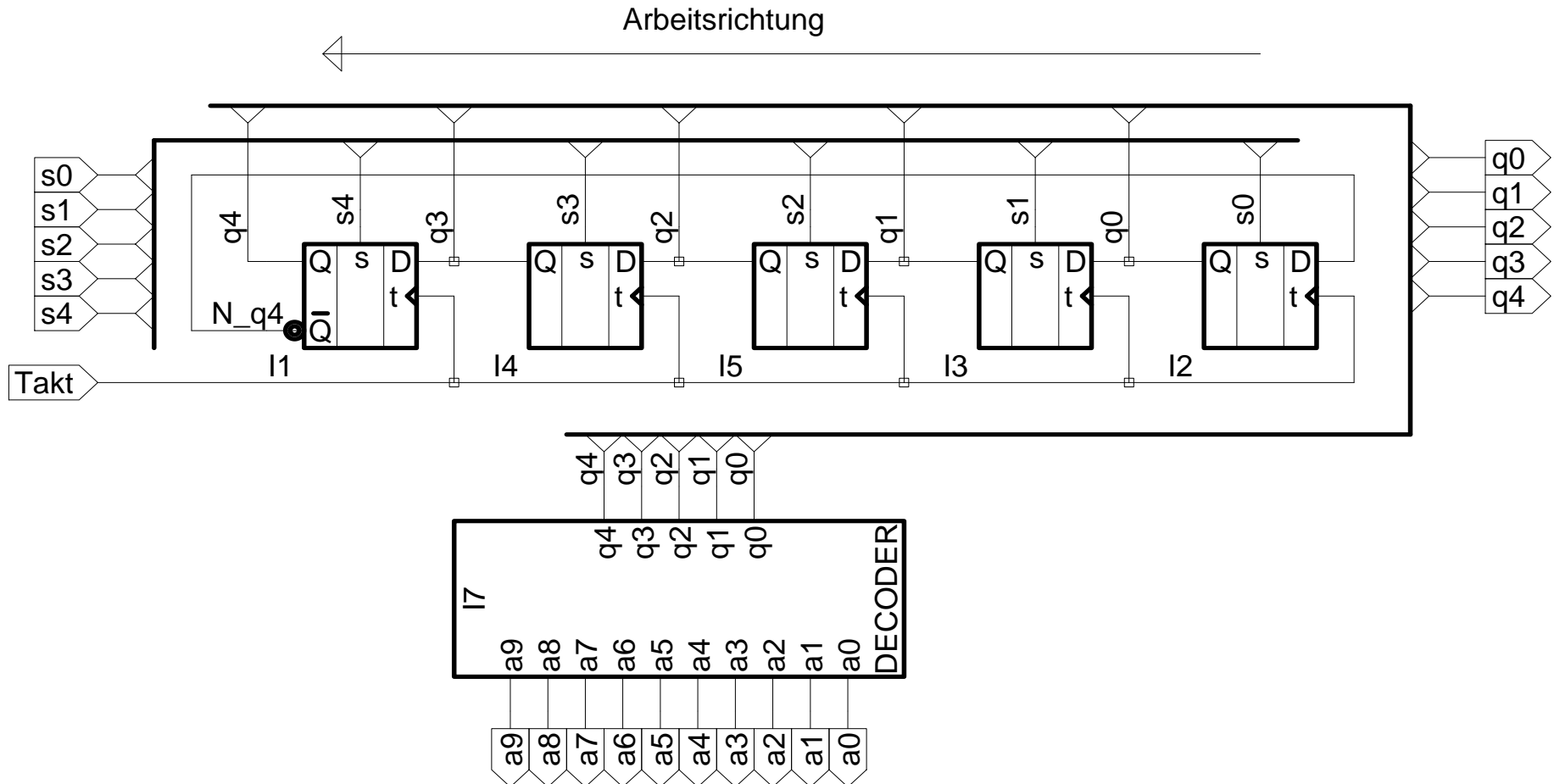

- a0 = !q4 & !q0 ;
- a1 = !q1 & q0 ;
- a2 = !q2 & q1 ;
- a3 = !q3 & q2 ;
- a4 = !q4 & q3 ;
- a5 = q4 & q0 ;
- a6 = q1 & !q0 ;
- a7 = q2 & !q1 ;
- a8 = q3 & !q2 ;
- a9 = q4 & !q3 ;

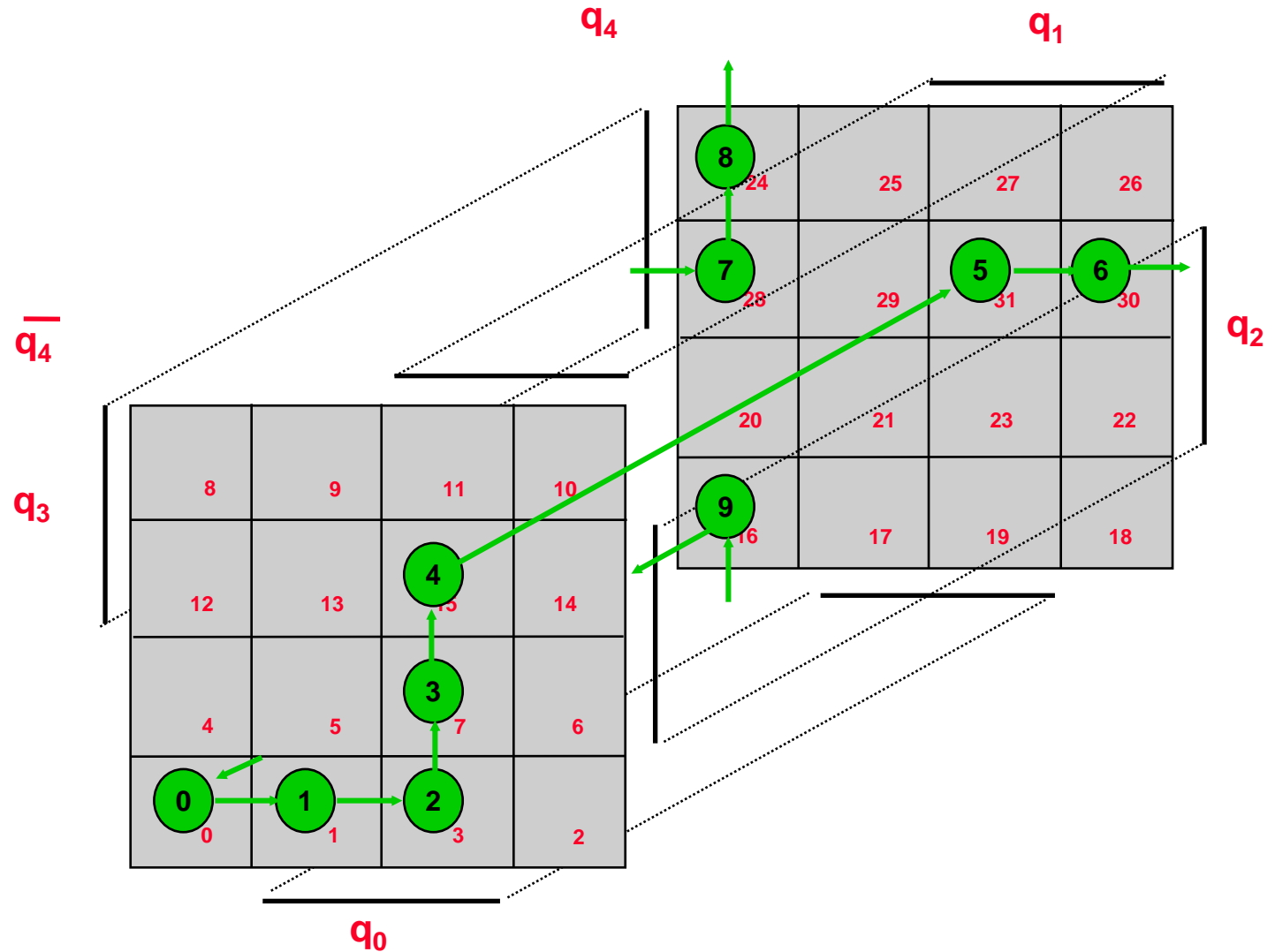

- a9 = $q4 \ \& \ !q2 \ \& \ q0$;
- a8 = $!q4 \ \& \ q3 \ \& \ !q1$;
- a7 = $q4 \ \& \ q2 \ \& \ !q0$;
- a6 = $q4 \ \& \ q3 \ \& \ q1$;
- a5 = $q3 \ \& \ q2 \ \& \ !q1$;
- a4 = $q3 \ \& \ q2 \ \& \ q1$;
- a3 = $q4 \ \& \ !q3 \ \& \ q1$;
- a2 = $!q4 \ \& \ !q2 \ \& \ q0$;
- a1 = $!q4 \ \& \ !q3 \ \& \ !q1$;
- a0 = $!q4 \ \& \ !q3 \ \& \ q1$;

q₃

8	9	2	10
12	13	15	4
4	1	7	6
0	1	3	0

q₀

q₄

24	25	27	6
28	5	31	30
7	21	3	22
16	9	19	18

q₂

q₁

$$\begin{aligned} a9 &= q4 \& \!q2 \& q0 \ ; \\ a9 &= q4 \& \!q2 \& \!q1 \ ; \\ a9 &= q4 \& \!q3 \& \!q2 \ ; \\ a9 &= \!q2 \& \!q1 \& q0 \ ; \\ a9 &= \!q3 \& \!q2 \& q0 \ ; \\ a9 &= \!q3 \& \!q2 \& \!q1 \ ; \end{aligned}$$

$$\begin{aligned} a8 &= \!q4 \& q3 \& \!q1 \ ; \\ a8 &= \!q4 \& \!q2 \& \!q1 \ ; \\ a8 &= q3 \& \!q1 \& \!q0 \ ; \\ a8 &= \!q2 \& \!q1 \& \!q0 \ ; \\ a8 &= \!q4 \& \!q1 \& \!q0 \ ; \\ a8 &= q3 \& \!q2 \& \!q1 \ ; \end{aligned}$$

$$\begin{aligned} a7 &= q4 \& q2 \& \!q0 \ ; \\ a7 &= \!q3 \& \!q1 \& \!q0 \ ; \\ a7 &= q2 \& \!q1 \& \!q0 \ ; \\ a7 &= \!q3 \& q2 \& \!q0 \ ; \\ a7 &= q4 \& \!q1 \& \!q0 \ ; \\ a7 &= q4 \& \!q3 \& \!q0 \ ; \end{aligned}$$

$$\begin{aligned} a6 &= q4 \& q3 \& q1 \ ; \\ a6 &= q4 \& \!q2 \& \!q0 \ ; \\ a6 &= q4 \& \!q2 \& q1 \ ; \\ a6 &= q4 \& q3 \& \!q2 \ ; \\ a6 &= q4 \& q1 \& \!q0 \ ; \\ a6 &= q4 \& q3 \& \!q0 \ ; \end{aligned}$$

$$\begin{aligned} a5 &= q3 \& q2 \& \!q1 \ ; \\ a5 &= q4 \& q3 \& \!q1 \ ; \\ a5 &= q3 \& \!q1 \& q0 \ ; \\ a5 &= q4 \& q3 \& q2 \ ; \\ a5 &= q3 \& q2 \& q0 \ ; \\ a5 &= q4 \& q3 \& q0 \ ; \end{aligned}$$

$$\begin{aligned} a4 &= q3 \& q2 \& q1 \ ; \\ a4 &= \!q4 \& q2 \& \!q0 \ ; \\ a4 &= \!q4 \& q2 \& q1 \ ; \\ a4 &= \!q4 \& q3 \& q2 \ ; \\ a4 &= q2 \& q1 \& \!q0 \ ; \\ a4 &= q3 \& q2 \& \!q0 \ ; \end{aligned}$$

$$\begin{aligned} a3 &= q4 \& \!q3 \& q1 \ ; \\ a3 &= q4 \& q2 \& q1 \ ; \\ a3 &= \!q3 \& q1 \& q0 \ ; \\ a3 &= q2 \& q1 \& q0 \ ; \\ a3 &= q4 \& q1 \& q0 \ ; \\ a3 &= \!q3 \& q2 \& q1 \ ; \end{aligned}$$

$$\begin{aligned} a2 &= \!q4 \& \!q2 \& q0 \ ; \\ a2 &= q3 \& q1 \& q0 \ ; \\ a2 &= \!q2 \& q1 \& q0 \ ; \\ a2 &= q3 \& \!q2 \& q0 \ ; \\ a2 &= \!q4 \& q1 \& q0 \ ; \\ a2 &= \!q4 \& q3 \& q0 \ ; \end{aligned}$$

$$\begin{aligned} a1 &= \!q4 \& \!q3 \& \!q1 \ ; \\ a1 &= \!q4 \& q2 \& q0 \ ; \\ a1 &= \!q4 \& q2 \& \!q1 \ ; \\ a1 &= \!q4 \& \!q3 \& q2 \ ; \\ a1 &= \!q4 \& \!q1 \& q0 \ ; \\ a1 &= \!q4 \& \!q3 \& q0 \ ; \end{aligned}$$

$$\begin{aligned} a0 &= \!q4 \& \!q3 \& q1 \ ; \\ a0 &= \!q3 \& q1 \& \!q0 \ ; \\ a0 &= \!q4 \& \!q3 \& \!q2 \ ; \\ a0 &= \!q3 \& \!q2 \& \!q0 \ ; \\ a0 &= \!q4 \& \!q3 \& \!q0 \ ; \\ a0 &= \!q3 \& \!q2 \& q1 \ ; \end{aligned}$$

$a_9 = \neg q_2 \ \& \ \neg q_0 ;$
 $a_8 = q_4 \ \& \ \neg q_1 ;$
 $a_7 = q_3 \ \& \ \neg q_0 ;$
 $a_6 = q_4 \ \& \ q_2 ;$
 $a_5 = q_3 \ \& \ q_1 ;$
 $a_4 = q_2 \ \& \ q_0 ;$
 $a_3 = \neg q_4 \ \& \ q_1 ;$
 $a_2 = \neg q_3 \ \& \ q_0 ;$
 $a_1 = \neg q_4 \ \& \ \neg q_2 ;$
 $a_0 = \neg q_3 \ \& \ \neg q_1 ;$

